

PowerCool Series Thermoelectric Cooler Assembly

The DA-034-12-02 is a Direct-to-Air Thermoelectric Cooler Assembly that uses impingement flow to transfer heat. It offers dependable, compact performance by cooling objects via conduction. Heat is absorbed through a cold plate and dissipated thru a high density heat exchanger equipped with an air ducted shroud and brand name fan. It has a maximum Qc of 34 Watts when $\Delta T = 0$ and a maximum ΔT of 41 °C at Qc = 0.

Features

- Compact design
- Precise temperature control
- Reliable solid-state operation
- Low noise
- RoHS-compliant

Applications

- Medical Diagnostic and Analytical Instrumentation
- Thermoelectric Coolers and Assemblies for Medical Applications
- Liquid Cooling Options for PET and SPECT Scanners
- Cooling for Centrifuges
- High-Performance Liquid Chromatography (HPLC)
- Heating and Cooling for Liquid Chromatography Systems
COLD SIDE

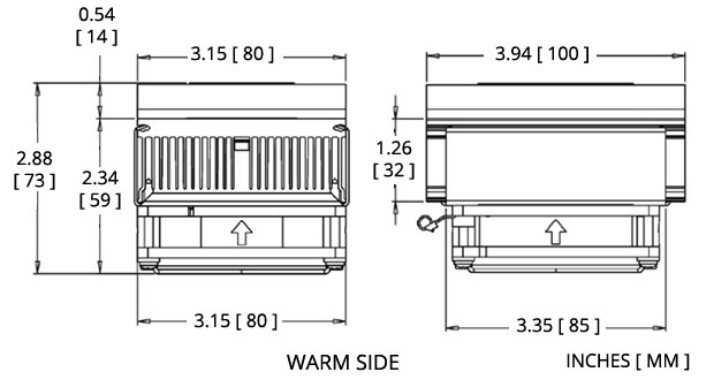

Electrical and Thermal Performance

Heat Pumped at Cold Side (Qc)
Tambient = 35°C

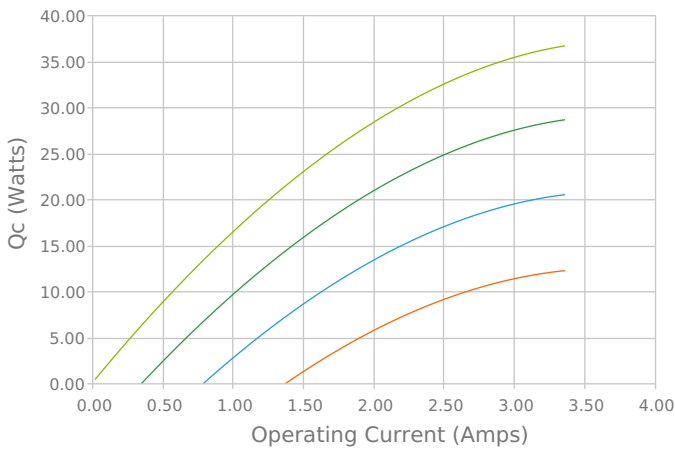

Heat Pumped at Cold Side (Qc)
Tambient = 35°C

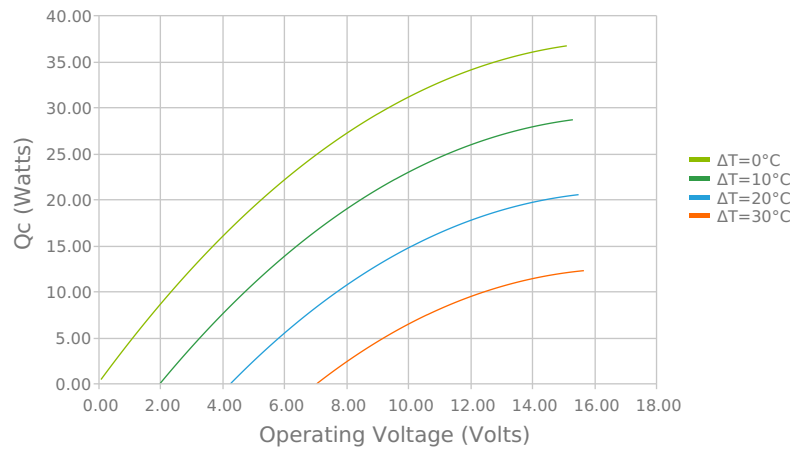

Coefficient of Performance (COP = Q_c/P_{in})
Tambient = 35°C

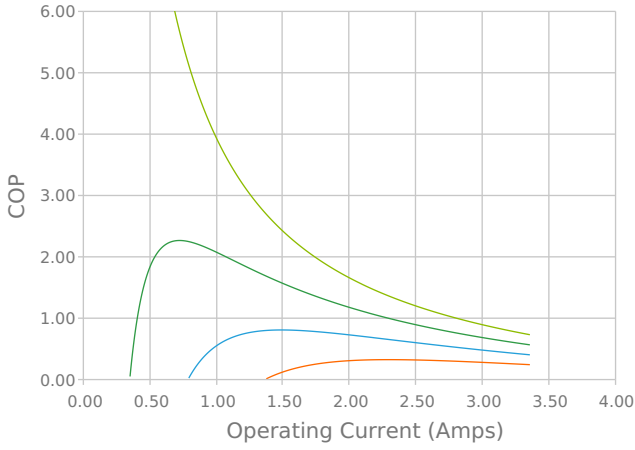

Coefficient of Performance (COP = Q_c/P_{in})
Tambient = 35°C

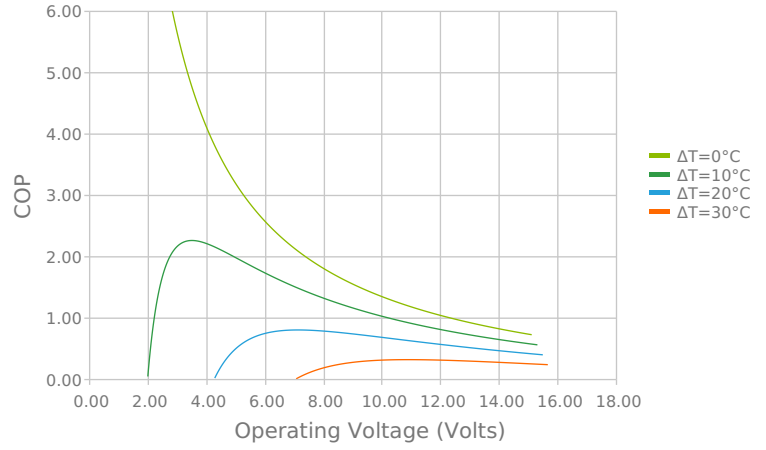

Total Heat Dissipated at Hot Side ($Q_h=Q_c+P_{in}$)
Tambient = 35°C

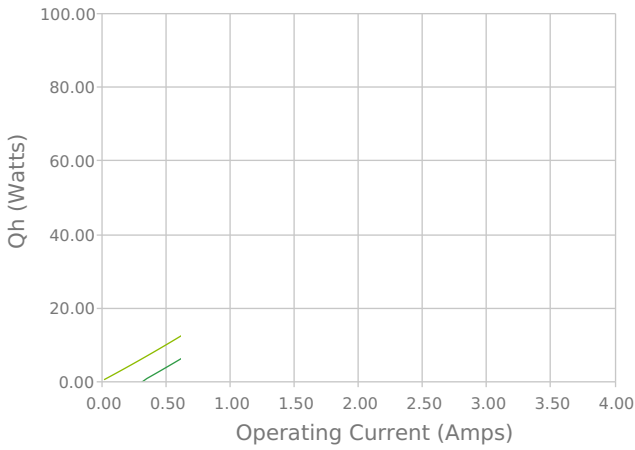

Total Heat Dissipated at Hot Side ($Q_h=Q_c+P_{in}$)
Tambient = 35°C

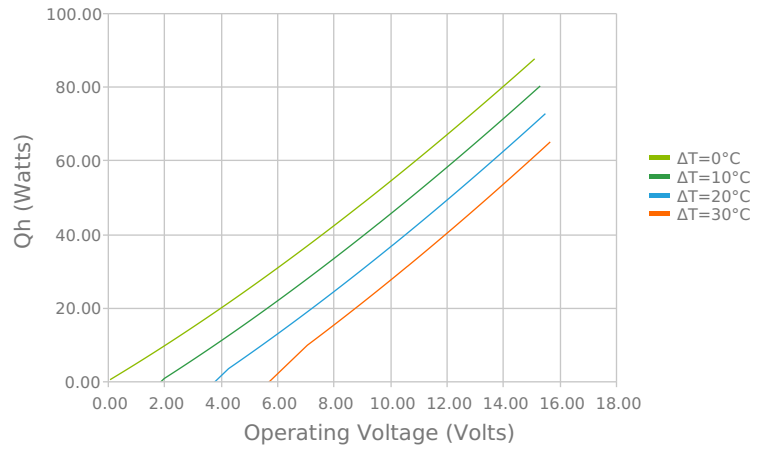

Heat Pumped at Cold Side (Q_c)
Voperating = 12 Volts | Ioperating = 2.73 Amps

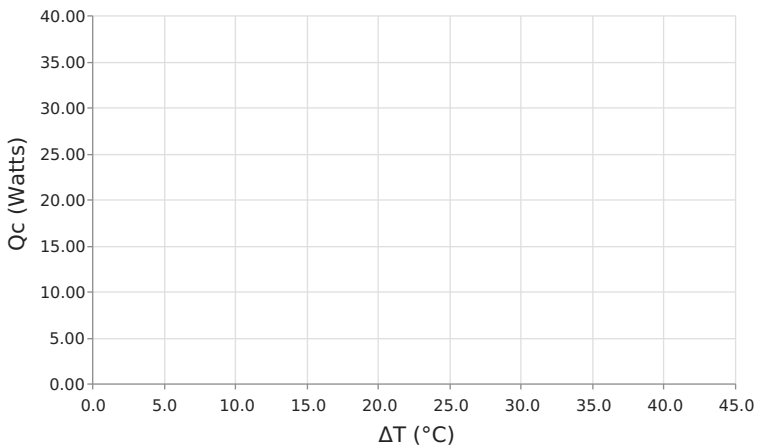

Coefficient of Performance (COP = Q_c/P_{in})
Voperating = 12 Volts | Ioperating = 2.73 Amps

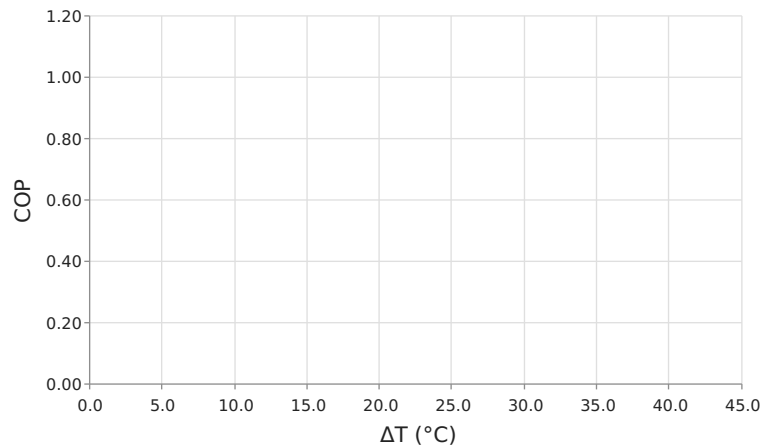

Specifications

Heat Transfer Mechanism, Cold Side	Direct - Conduction
Heat Transfer Mechanism, Hot Side	Air - Forced Convection
Operating Temperature Range	-10°C to 46°C
Supply Voltage	12.0 VDC nominal / 15.0 VDC maximum
Current Draw	2.6 A running / 3.2 A startup
Power Supply	31.0 Watts
Performance Tolerance	10%
Hi-Pot Testing	No Testing
Fan MTBF	50000 hours
Weight	0.45 kg
Panel Mounting	Flush Mount

Mounting Hole Location

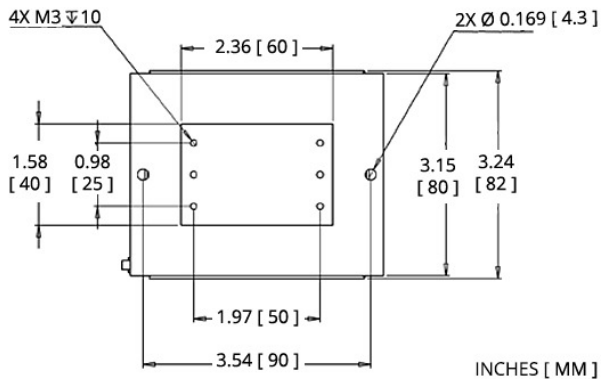

Wiring Schematic

ELECTRICAL CONNECTIONS:

TEM+ : Pink
 TEM - : Green
 FAN+ : Purple
 FAN - : Blue

Warning: Single supply not applicable in heating mode or with PWM-regulation.

Notes

¹For indoor use only

²Units are generally maintenance free, however occasionally it is recommended to clean the heat sinks and fans of debris. This is best done with compressed air.

Any information furnished by Tark Thermal Solutions and its agents, whether in specifications, data sheets, product catalogues or otherwise, is believed to be (but is not warranted as being) accurate and reliable, is provided for information only and does not form part of any contract with Tark Thermal Solutions. All specifications are subject to change without notice. Tark Thermal Solutions assumes no responsibility and disclaims all liability for losses or damages resulting from use of or reliance on this information. All Tark products are sold subject to the Tark Thermal Solutions Terms and Conditions of sale (including Tark's limited warranty) in effect from time to time, a copy of which will be furnished upon request.

© Copyright 2025 Tark Thermal Solutions, Inc. All rights reserved.

Revision: 01 Date: 04-30-2024

Print Date: 05-12-2025